

2000035155 A4

**BRITAX RÖMER Child Safety EMEA**

www.britax-roemer.com | hello@britax-roemer.com

## 2. Product description

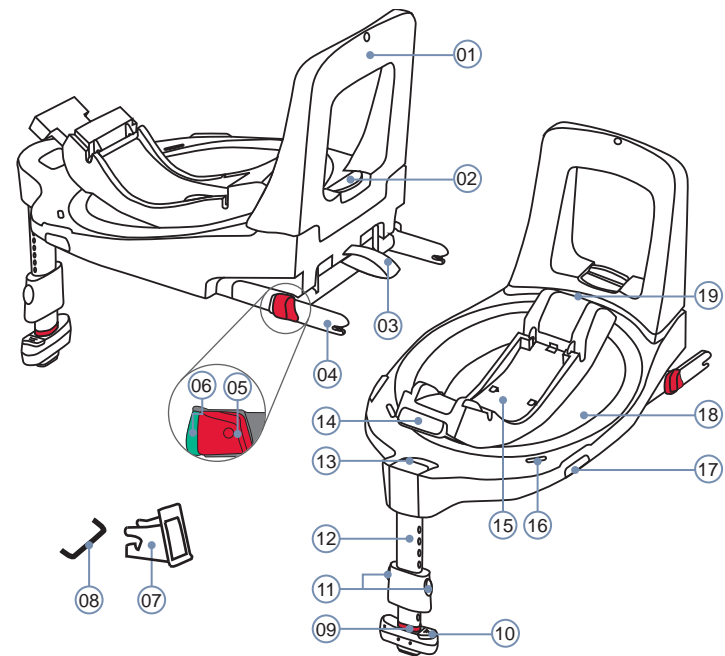

- 01 Shock bar
- 02 Adjustment button
- 03 Fabric loop
- 04 ISOFIX locking arms
- 05 Red locking button
- 06 Release button
- 07 Insert aids
- 08 ISOFIX installation bracket
- 09 Red support indicator
- 10 Battery cover
- 11 Support leg buttons
- 12 Support leg
- 13 Red swivel indicator
- 14 Unlock button
- 15 Storage compartment instructions
- 16 Red rotary function indicator
- 17 Rotary button
- 18 Rotary plate
- 19 Incline button

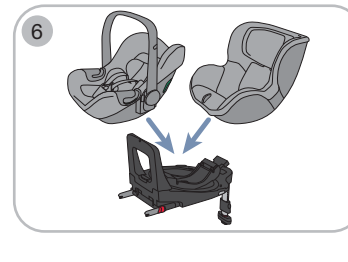
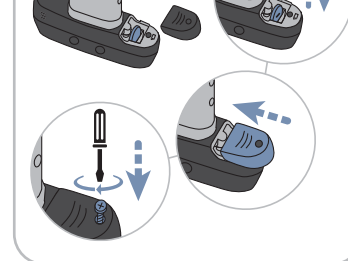
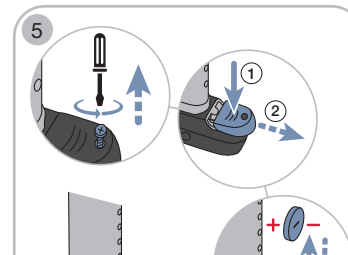
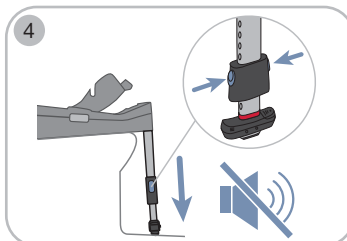
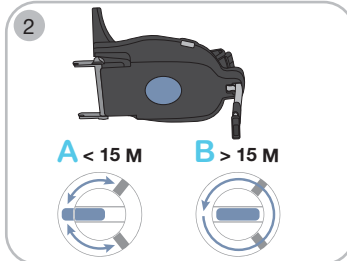
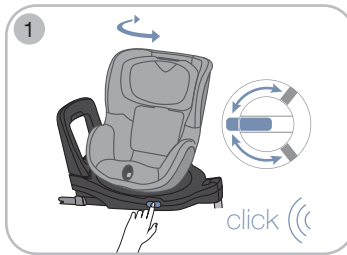

## Boarding and exit function

This function simplifies boarding and exit. Only use this function when the vehicle is parked.

### Operation 1

- ▶ Press rotary button.
- ▶ Rotate seat module.
- ▶ Secure or remove child in accordance with the seat module's operating instructions.
- ▶ Return seat module to original position.
  - ↳ Rotary plate audibly locks.
  - ↳ The red rotary function indicator is no longer visible.
- ▶ Check that the rotary plate is securely locked in place. Try to turn the seat module. If the seat module can no longer be turned, the rotary plate is securely locked in place.

## Direction of travel

The base station allows a seat module to be secured against the direction of travel (A) or in the direction of travel (B). Securing in the direction of travel (B) is only permitted with the DUALFIX iSENSE and DUALFIX 3 i-SIZE seat modules. To be able to use these seat modules in the direction of travel, the rotary lock must be released. The release button is on the bottom of the base station.

### Release rotary lock 2

- ▶ Move slider to the middle.
  - ↳ Rotary plate can be rotated 360°.

### Operation 3

- ▶ Press rotary button.
- ▶ Turn seat module to desired direction.
- ⚠ **WARNING!** Only use BABY-SAFE iSENSE and BABY-SAFE 3 i-SIZE against the direction of travel.
- ⚠ **WARNING!** Use DUALFIX iSENSE and DUALFIX 3 i-SIZE against the direction of travel for from 15 months.
  - ↳ Rotary plate audibly locks.
  - ↳ The red rotary function indicator is no longer visible.
- ▶ Check that the rotary plate is securely locked in place.
- ☞ If the seat module can no longer be turned, the rotary plate is securely locked in place.

## Acoustic support 4

The sensors in the support leg assist with correct installation. The sensors check whether the support leg is fully folded out, sufficiently extended and is on the floor.

### Activate acoustic support

- ☞ Only required before first use.
- ▶ Remove film.
  - ↳ Control signal is enabled.

⚠ **CAUTION!** Check battery regularly. If a signal cannot be heard, this means that the battery is empty.

### Change battery 5

- ▶ Undo screw.
- ▶ Hold cover down and push to one side.

⚠ **WARNING!** Remove the used battery and dispose of it in accordance with the chapter Disposal, see page 2. Store the battery out of the reach of children. Only use a new battery of type RC 2032. Note the polarity alignment. Never use a battery that has signs of a leak or bursting. Do not expose the battery to high temperatures or fire; the battery can burst or explode. Do not use rechargeable batteries. Note the safety information on the battery's packaging.

- ▶ Close cover.
- ▶ Fasten screw.

## 3. Intended use 6

This product has been designed, tested and certified according to the requirements of the European Standard for Child Safety Equipment UN ECE R129/03.

The FLEX BASE iSENSE is a base station. It is designed exclusively for securing one of the following seat modules in the vehicle. Other products must not be used with this base station.

## BABY-SAFE iSENSE & BABY-SAFE 3 i-SIZE:

	<b>Rear-facing</b>	<b>Never use the product forward-facing.</b>
<b>Body height</b>	40 - 83 cm	
<b>Body weight</b>	Maximum 13 kg	

## DUALFIX iSENSE & DUALFIX 3 i-SIZE:

	<b>Rear-facing</b>	<b>Forward-facing</b>
<b>Body height</b>	61 - 105 cm	76 - 105 cm
<b>Body weight</b>	Maximum 18 kg	

## 4. Safety information

### Risk of injury from damaged child seat

In the event of an accident at a collision speed of more than 10 km/h, the base station and the seat module may be damaged without the damage being immediately visible. Serious injuries may result from another accident.

- ▶ Replace product following an accident.
- ▶ Have damaged product inspected (even if it has fallen onto the ground).
- ▶ Regularly check all important parts for damage.
- ▶ Ensure that all mechanical components work properly.
- ▶ Never lubricate or oil parts of the product.
- ▶ Properly dispose of the damaged product.

### Risk of burns from hot components

Components of the product can become hot in direct sunlight. Children's skin is sensitive and maybe harmed as a result.

- ▶ Protect the product against intensive direct sunlight when not in use.

### Risk of injury if installed incorrectly

If the product is installed or used other than as described in the operating instructions, serious or even fatal injuries may result.

- ▶ Only use on a car seat facing the direction of travel.
- ▶ Note and follow the instructions in the vehicle handbook.

### Risk of injury from front airbag

Airbags are designed to protect adults. If the child seat is too close to the front airbag, slight or serious injuries can arise.

- ▶ For rear-facing use, disable front airbag.
- ▶ If the child seat is secured on the passenger seat, slide the passenger seat backwards.
- ▶ If the child seat is secured on the second or third row of seats, slide the corresponding front seat forwards.
- ▶ Note and follow the instructions in the vehicle handbook.

### Risk of injury during use

The temperature in a vehicle can rise dangerously quickly. In addition, it is dangerous to leave the vehicle on the side facing the street.

- ▶ Never leave a child unsupervised in the vehicle.
- ▶ Only fasten or remove seat module from the footpath-side.
- ▶ Only allow the child to board and disembark on the footpath-side.
- ▶ On long journeys, take regular breaks in order to give your child chance to run about and play.

### Risk of injury from unsecured objects

In the case of an emergency stop or accident, unsecured objects or people may cause injury to other occupants in the vehicle.

- ▶ **Never** secure your child by holding them tightly on your lap.
- ▶ Secure backrests of the vehicle find (e.g. engage foldable rear).
- ▶ Secure all heavy or sharp-edged objects in the vehicle (e.g. on the parcel shelf).
- ▶ Do not place objects in the foot well.
- ▶ Ensure that everyone in the vehicle has their seatbelts fastened.
- ▶ Ensure that the product is always secured when it is in the car, even if no baby is being transported.

## 1. About this document

⚠ **WARNING!** This operating manual is a component of the product and contributes to its safe use. Non-compliance may lead to serious or even fatal injuries. If in doubt, do not use product and immediately contact your retailer.

- ▶ Read operating instructions.
- ▶ Keep with the product for reference.
- ▶ If the product is given to third parties, include the operating instructions with the product.

## Contact information

If there are any questions, please get in touch.

### BRITAX RÖMER Child Safety EMEA

www.britax-roemer.com  
hello@britax-roemer.com

### BRITAX RÖMER Kindersicherheit GmbH

Theodor-Heuss-Strasse 9  
89340 Leipzig  
Germany

+49 (0) 8221 3670 199

### BRITAX Excelsior Limited

1 Churchill Way West  
Andover  
Hampshire SP10 3UW  
United Kingdom

+44 (0) 1264 386034

### BRITAX Nordiska Barn AB

Jörgen Kocksgatan 4  
SE-211 20 Malmö  
Sweden



## Risk of injury to spine

An infant carrier is not intended to hold a child for prolonged periods of time. The semi-recumbent position in the infant carrier will always put a strain on the child's spine.

- ▶ Take breaks on long journeys.
- ▶ Take the child out of the infant carrier as often as possible.
- ▶ Do not keep your child in the infant carrier once it has been removed from the car.

## Risk of injury from unsecured child

If the child causes the car seat belt lock to open, in the event of an emergency stop or an accident there is a risk of serious or even fatal injuries.

- ▶ Stop safely as soon as this is possible.
- ▶ Ensure that the child seat is correctly fastened.
- ▶ Ensure that your child is correctly buckled up correctly.
- ▶ Explain the consequences and dangers to the child.

## Avoid damaging the product

- ▶ Never use product in a free-standing position, even for testing.
- ▶ Product is not a toy.
- ▶ Ensure that the product is not trapped between hard objects (car door, seat rails, etc.).
- ▶ Keep product away from: Damp, moisture, liquids, dust and salt spray.
- ▶ Do not lean heavy objects on the product.

## Risk of injury as a result of prohibited modification

This approval is invalidated if you make any modifications to this product. Changes may only be made by the manufacturer. The stickers on the product are an important component of the product.

- ▶ Do not make any changes.
- ▶ Do not remove stickers.

## How to avoid damaging the vehicle

- ▶ Sensitive car seat covers may be damaged.
- ▶ Use a BRITAX RÖMER child seat base. These are available separately.

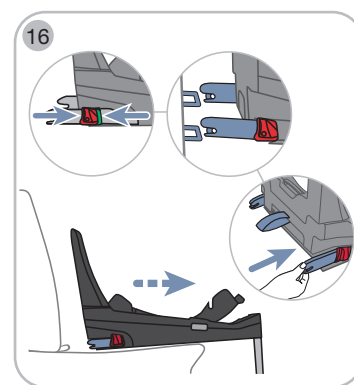
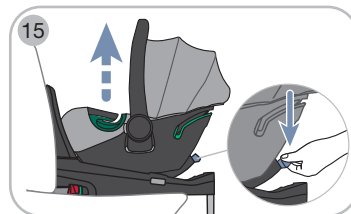
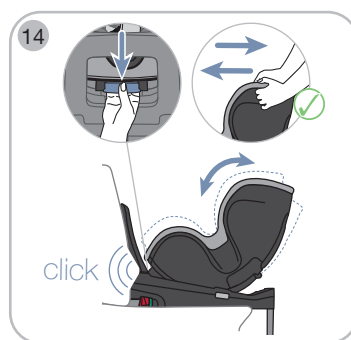

# 5. Use in the vehicle

## Secure base station

### 1. Select suitable seat

**⚠ WARNING!** Note and follow the vehicle's operating instructions.

- ☞ Car seats with i-Size approval are suitable.
- ☞ Suitable car seats with ISOFIX installation bracket, which have been tested and approved by us. These are shown in our model list at [www.britax-roemer.com](http://www.britax-roemer.com)
- ☞ Only car seats arranged in the direction of travel are approved for use.

### 2. Position base station 7

- ▶ Fold out support leg.
- ▶ Position base station on the car seat.

### 3. Adjust shock bar 8

- ▶ Hold adjustment button down.
- ▶ Adjust shock bar to the backrest of the car seat.
- ▶ Release adjustment button.
- ↳ Shock bar audibly locks.
- ▶ Check that the shock bar is securely locked in place.
- ☞ If the shock bar can no longer be adjusted, then it is securely locked in place.

### 4. Checking ISOFIX 9

- ▶ Check whether the ISOFIX locking arms are open.
- ☞ The ISOFIX locking arms are open if a green area is not visible.
- ▶ If the ISOFIX locking arms are closed, then press the locking button and the release button together.

### 5. Fastening the ISOFIX 10

- ▶ Attach applicator.
- ☞ The applicators help simplify connecting the ISOFIX locking arms of the product to the vehicle's ISOFIX installation bracket.
- ▶ Pull the grey fabric loop.
- ↳ ISOFIX locking arms are extended fully.
- ▶ Insert both ISOFIX locking arms into the applicators and connect to the ISOFIX installation brackets.
- ↳ ISOFIX locking arms audibly lock.
- ↳ The green area is visible on both ISOFIX locking arms.
- ↳ ISOFIX is connected.
- ▶ Push the base station as far as possible against the backrest of the car seat.

### 6. Check the ISOFIX fastening 11

- ▶ Check that the ISOFIX locking arms are connected to the ISOFIX installation brackets on both sides. Pull the base station. If neither of the ISOFIX locking arms can be released, then both are securely connected to the vehicle.
- ↳ The green area is visible on both ISOFIX locking arms.
- ↳ ISOFIX is connected.

### 7. Setting support leg 12

- ▶ Make sure that the acoustic support is active. If the control signal cannot be heard, check the charge level of the battery. Replace the battery if necessary. See chapter "Acoustic support" page 1.
- ▶ Fold support leg fully away from the base station.
- ↳ Support leg audibly locks.
- ↳ The red rotary function indicator is no longer visible.
- ▶ Hold down support leg buttons.
- ▶ Extend support leg to the floor of the vehicle.
- ⚠ WARNING!** Never place objects under the support leg.
- ↳ The red support indicator is no longer visible.
- ↳ Control signal can no longer be heard.
- ↳ Bottom of the base station is on the seat of the car seat.

## Secure seat module to base station

### 1. Secure module 13

**⚠ WARNING!** Do not use the BABY-SAFE iSENSE and BABY-SAFE 3 i-SIZE seat modules facing forwards.

**⚠ WARNING!** For rear-facing use, **disable** front airbag.

- ▶ Make sure that there are no foreign objects on the base station.
- ▶ For infant carriers, make sure that the handle is in the top position A and the child is secured into the infant carrier.
- ▶ Note alignment of the rotary plate on the base station.
- ☞ Each seat module can only be connected to the rotary plate in a specific direction. The back of the seat module must face the unlock button.
- ▶ Lock seat module to the base station.
- ↳ Seat module audibly locks.
- ▶ Check that the seat module is securely locked in place.
- ☞ Try to lift the seat module. If the seat module cannot be lifted from the base station, the seat module is securely locked in place.
- ▶ Check distance between seat module and front seat.
- ↳ Distance must be more than 10 cm.
- ▶ If the distance is less than 10 cm, slide the front seat forwards. If this is not possible, release the seat module and base station and select a different car seat for fastening.

### 2. Set angle of incline 14

- ☞ This station allows the angle of seat the module to be set. This allows compensation for different car seat angles.
- ▶ Hold incline button down.
- ▶ Incline seat module as desired.
- ▶ Release incline button.
- ↳ Position audibly locks.
- ▶ Check that angle function is securely locked in place.
- ☞ If the seat module can no longer be tilted, the angle function is securely locked in place.

## Check before every use

- The green area is visible on both ISOFIX locking arms.
- The red rotary function indicator is not visible.
- The red support indicator is not visible.
- The support leg is directly on the floor.
- Control signal **cannot** be heard.
- Bottom of the base station is on the seat of the car seat.
- The red rotary function indicator is not visible.
- Seat module is securely fastened to the base station.
- Shoulder belts are correctly adjusted.
- Child is correctly strapped in.

## When using an infant carrier, please also note

- Infant carrier is secured facing **away from** the direction of travel.
- If the vehicle has a front airbag, it is **disabled**.
- Handle is in the upper position A.

## Loosen seat module from the base station 15

- ▶ For infant carriers, make sure that the handle is in the top position A and the child is secured into the infant carrier.
- ▶ Press unlock button.
- ▶ Hold seat module and lift.
- ▶ Remove seat module from the vehicle.

## Loosen base station 16

- ▶ Push the locking button and release button on the two ISOFIX locking arms together.
- ↳ Locking arms are released.
- ▶ Push ISOFIX locking arms into the base station.
- ▶ Remove base station from the vehicle.

# 6. Cleaning and care

- ▶ Clean plastic parts with soapy water.
- ▶ Do not use abrasive cleaning agents (e.g. solvents).

# 7. Temporary storage of product

If you do not use the product for a longer period, please note the following information.

- ▶ Store product in a secure and dry location.
- ▶ Maintain storage temperature between 20 and 25 °C.
- ▶ **Do not** lean heavy objects on the product.
- ▶ **Do not** store product directly next to sources of heat or in direct sunlight.
- ▶ Disable acoustic support.
- ▶ Fold in support leg.
- ▶ Store base station horizontally.

# 8. Disposal

Please follow the disposal regulations applying in your country.

Packaging	Container for cardboard boxes
Seat cover	Residual waste, thermal recycling
Plastic parts	To be placed in the corresponding container as labelled
Metal parts	Container for metals
Belt straps	Container for polyester
Buckle and clip	Residual waste
Battery	Container for batteries 